

NEW EUROSFILO HQ
HIGH QUALITY

13 | 14 | 17 | 19

Tecnologia e sicurezza per lavorare in quota
Safety and technology for aerial works
Technologie et sécurité pour travaux aériens
Technologie und Sicherheit bei der Arbeit in der Höhe
Tecnología y seguridad por trabajos aéreos
Технология и безопасность для работы на высоте

Since 1960
COMET
OFFICINE



- Altezza di lavoro da 13 a 19 m
- Sbraccio laterale fino a 14 m
- **Non necessitano di limitatore di sbraccio laterale (100% SAFE) i modelli: NEW EUROSFILO 13|2|7.5 HQ e NEW EUROSFILO 14|2|9 HQ e i modelli installati su camion superiori a 3.5 ton**
- Limitatore di carico sugli altri modelli
- Disponibile versione con stabilizzatori verticali in sagoma per tutti i modelli
- Comandi 100% idraulici e con sistema proporzionale a bassa pressione in navicella (solo 25 BAR)
- Rotazione continua della torretta a 360°
- Rotazione idraulica della navicella 90°+90°
- Presa elettrica 230 V in navicella
- Contatore in cabina



- Working height from 13 to 19 m
- Lateral outreach up to 14 m
- **No need of any device to limit lateral outreach (100% SAFE) for NEW EUROSFILO 13|2|7.5 HQ and NEW EUROSFILO 14|2|9 HQ or for models mounted on heavy truck**
- Sensing limiting device in other models
- Version with vertical within vehicle footprints (in shape outriggers) for all the available models
- 100% hydraulic controls with proportional system in low pressure in the basket (25 BAR only)
- 360° continuous rotation of turret
- 90°+90° hydraulic basket rotation
- Electric power socket 230 V in basket
- Hour-counter in the cabin



- Hauteur de travail de 13 à 19 m
- Déport latéral jusqu'à 14 m
- **Il n'y a pas besoin de dispositif de limitation du déport latéral (100% SAFE) pour NEW EUROSFILO 13|2|7.5 HQ, NEW EUROSFILO 14|2|9 HQ et pour les modèles installés sur le camion supérieur à 3.5 ton**
- Système de limitation de charge pour les autres modèles
- Disponible version avec stabilisateurs verticaux en gabarit pour tous les modèles
- Commandes 100% hydrauliques et en basse pression (que 25 BAR) dans le panier
- Rotation continue de la tourelle 360°
- Rotation hydraulique du panier 90°+90°
- Prise électrique 230 V dans le panier
- Compte-heure dans la cabine



- Arbeitshöhe zum 13 bis 19 m
- Seitliche Reichweite bis 14 m
- **Modelle auch erhältlich ohne seitliche Reichweitenbegrenzung (100% SAFE): NEW EUROSFILO 13|2|7.5 HQ, NEW EUROSFILO 14|2|9 HQ und modelle auf schweren LKW (3.5 ton)**
- Schaltbegrenzungseinrichtung in andere Modelle
- Versionen mit vertikalen Abstützungen innerhalb der Fahrzeugkontur, für alle Modelle verfügbar
- Direkte vollhydraulische Steuerung mit proportionalem Niederdrucksystem (nur 25 BAR) im Arbeitskorb
- Endlose Turmdrehung um 360°
- Hydraulische Korbdrehung 90°+90°
- Stromanschluss für 230 V Wechselstrom im Arbeitskorb
- Stundenzähler im Führerhaus



- Altura de trabajo a partir el 13 de 19 m
- Alcance lateral hasta 14 m
- **Modelos sin necesidad de ningún dispositivo para limitar la extensión lateral (100% SAFE): NEW EUROSFILO 13|2|7.5 HQ y NEW EUROSFILO 14|2|9 HQ y para los modelos su camion superior à 3.5 ton**
- Dispositivo de limitacion en otros modelos
- Versión con estabilizadores formados verticales y disponible en todos los modelos
- 100% de los controles hidráulicos con sistema proporcional en baja presión en la cesta (25 BAR)
- 360° de rotación continua de la torreta
- 90°+90° hidráulica rotación de la cesta
- Toma de corriente de 230 V en la cesta
- Contador de horas de uso de la plataforma está ubicado en la cabina



- Рабочая высота от 13 м до 19 м
- Боковой вылет 14 м
- **Нет необходимости в любом устройстве, чтобы ограничить боковой охват (100 % SAFE) для новых EUROSFILO 13|2|7.5 HQ и новые EUROSFILO 14|2|9 HQ или для моделей, установленных на тяжелых грузовиков (3.5 ton)**
- Чувствительный устройство ограничения в других моделях
- Имеется версия с вертикальными стабилизаторами, не выходящими из габаритов на всех моделях
- 100% гидравлическое управление на низком давлении (всего 25 бар) с пропорциональной системой
- Непрерывное вращение башни на 360 градусов
- Гидравлический поворот люльки на 90°+90°
- Наличие электрической розетки 230 В в люльке
- Считыватель рабочих часов в кабине

**NEW EUROSFILO** HQ
HIGH QUALITY

13 | 14 | 17 | 19

**momulose**

Calle Cuenca, 6, 45940, Valmojado, Toledo, España
Tlf. 919218436 momulose@momulose.com
www.momulose.com



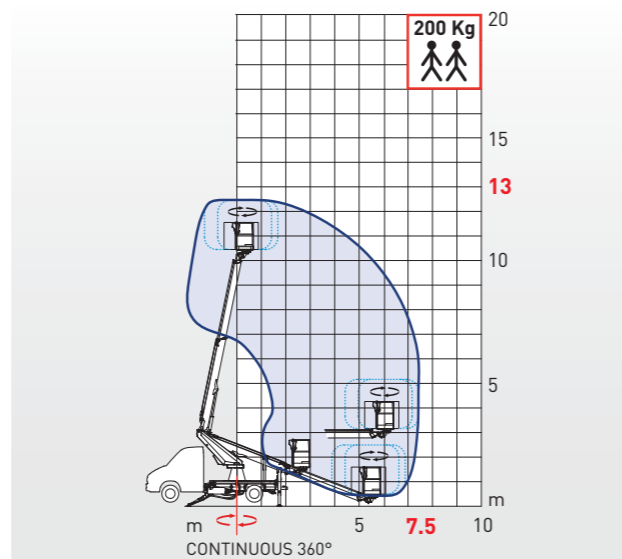

12.5 m	7.5 m	200 kg	* 360°	90°+ 90°

* 360° Continui * Continuous 360° * 360° Continus * 360° Stufenlos * 360° Непрерывное

Min. GVW 3.5 Ton
Within vehicle footprints (in shape outriggers H type)

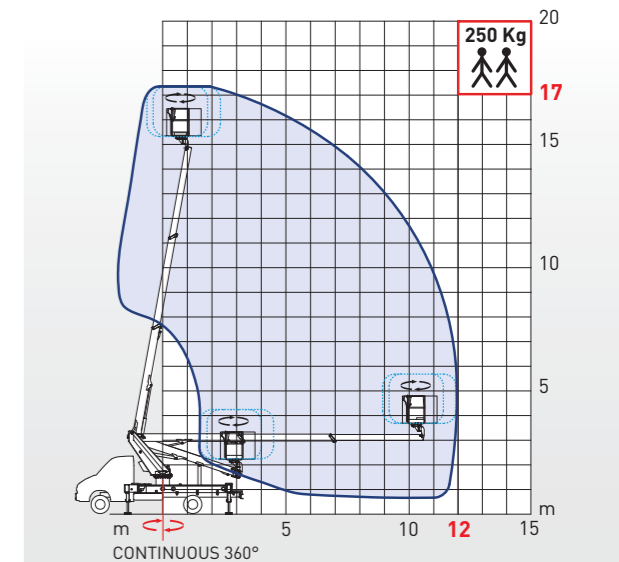
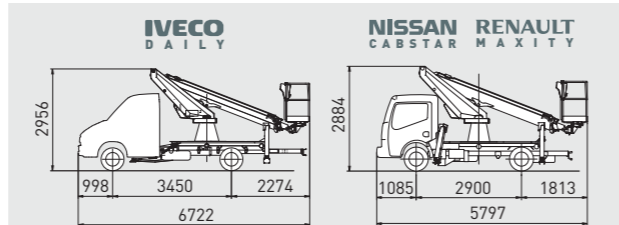

17 m	12 m	250 kg	* 360°	90°+ 90°

* 360° Continui * Continuous 360° * 360° Continus * 360° Stufenlos * 360° Непрерывное

17	2	8.5	HQ
17	2	11	HQ

Min. GVW 3.5 Ton
All available within vehicle footprints (in shape outriggers H type)

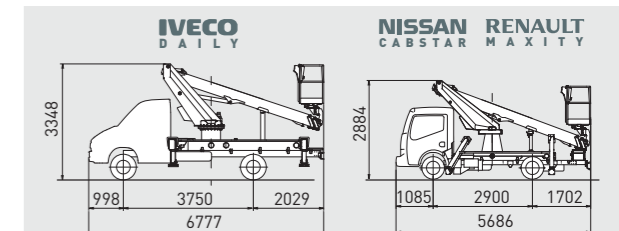

Lateral outreach depending on truck GVW

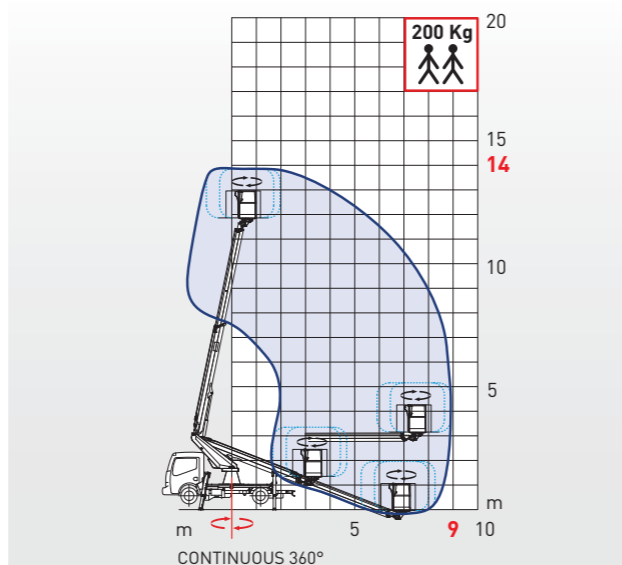

14 m	9 m	200 kg	* 360°	90°+ 90°

* 360° Continui * Continuous 360° * 360° Continus * 360° Stufenlos * 360° Непрерывное

Min. GVW 3.5 Ton
Within vehicle footprints (in shape outriggers H type)

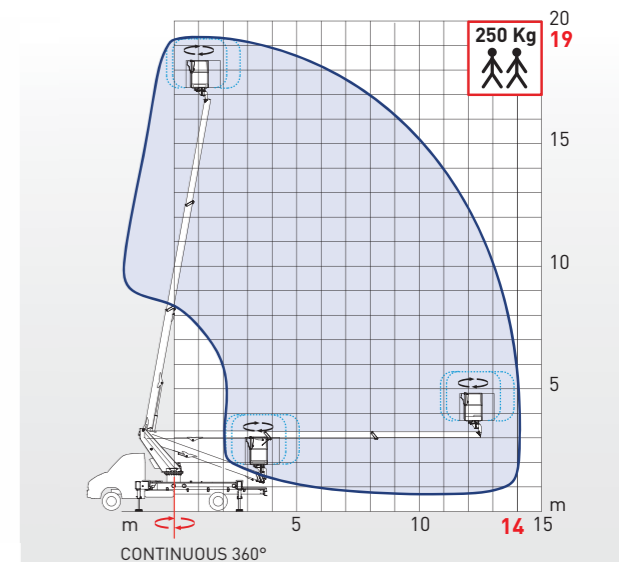
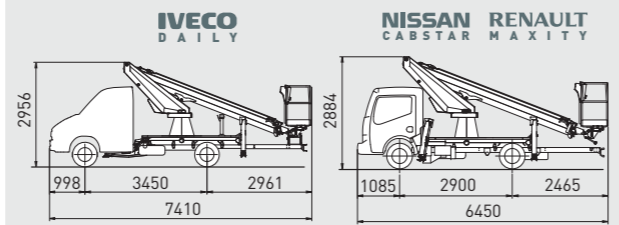

19 m	14 m	250 kg	* 360°	90°+ 90°

* 360° Continui * Continuous 360° * 360° Continus * 360° Stufenlos * 360° Непрерывное

19	2	8.5	HQ
19	2	11	HQ

Min. GVW 3.5 Ton
All available within vehicle footprints (in shape outriggers H type)

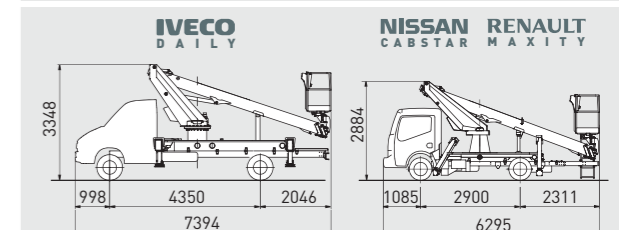

Lateral outreach depending on truck GVW